

**STRAIGHT BULKHEAD JACK PANEL SEAL
SOLDER TYPE - CABLE .085 - PACK. 100**

R124.326.043
SERIES SMA-COM

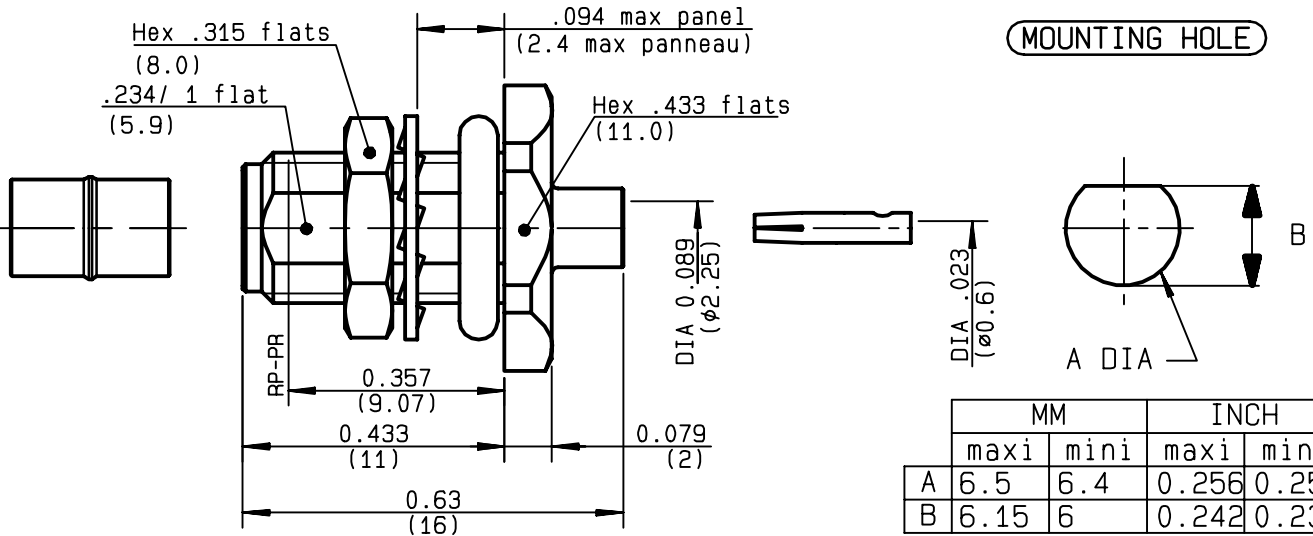

| | |
|---------------------------------|---------------------------------------|
| NOMINAL IMPEDANCE | 50 Ω |
| FREQUENCY RANGE | 0-18 GHz |
| TEMPERATURE RATING | -65/+105 °C |
| V.S.W.R | 1.07 + .01 x F(GHz)Maxi |
| RF INSERTION LOSS | 0.05 √F(GHz) dB Maxi |
| VOLTAGE RATING | 335 Veff Maxi |
| DIELECTRIC WITHSTANDING VOLTAGE | 750 Veff Mini |
| INSULATION RESISTANCE | 5000 MΩMini |
| HERMETIC SEAL | NA Atm.cm ³ /s |
| LEAKAGE (pressurized only) | NA |
| MECHANICAL DURABILITY | 100 Cycles |
| WEIGHT | 3.45 gr |
| SPECIFICATION | |

CABLES : **KS 1**
RG 405

OTHERS CHARACTERISTICS

POSITIVE KNEE INSERT CAPTIVATION

| | |
|----------------------------|---------------------|
| CABLE RETENTION | 130 N Mini |
| CENTER CONTACT RETENTION | |
| Axial force - mating end | NA N Mini |
| Axial force - opposite end | NA N Mini |
| Torque | NA cm.N Mini |
| RECOMMENDED TORQUES | |
| Mating | NA cm.N |
| Panel nut | 150 cm.N |
| Clamp nut | NA cm.N |

| | | | |
|-----------------|------------------|------------------------|---------------------------------------|
| CONNECTOR PARTS | MATERIALS | FINISH | (all values are given in micrometers) |
| BODY | BRASS | GOLD 0.5 OVER NICKEL 2 | |
| OUTER CONTACT | | | |
| CENTER CONTACT | BERYLLIUM COPPER | GOLD 1.3 OVER NICKEL 2 | |
| INSULATOR | PTFE | - | |
| GASKET | SILICONE RUBBER | - | |
| OTHERS PIECES | BRASS | GOLD 0.2 OVER NICKEL 2 | |

| | | |
|----------------|-------------------|--------------------|
| ISSUE | CREATION DATE | FILE PART-NUMBER |
| 9847A00 | 25/06/1997 | 97-0105-201 |



TRIQUES

The information given here is subject to change without notice. Design changes may be in order to improve the product .

Connect to the future



R124.326.043

ISSUE **9847A00** SERIES **SMA-COM**

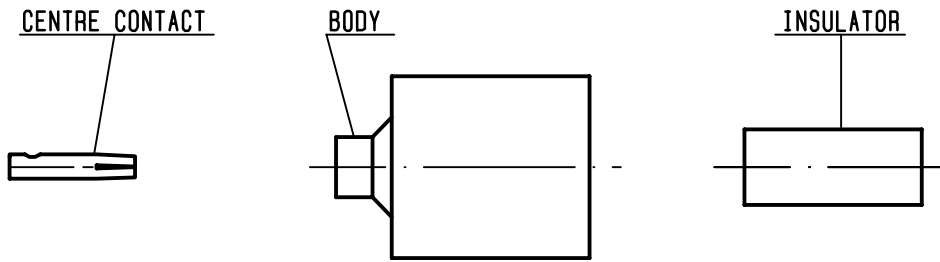

We recommend a cable thermal preconditioning before assembling

①

Take the tool kit : R282.120.010
Strip the dielectric of the cable .
Stripping tool cable : R282.051.000
Trimmer : R282.063.000
Clean the cable .
-

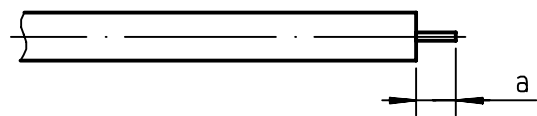

| Stripping | a | b | c | d | e |
|-----------|--------|---|---|---|---|
| inch | 0.1250 | 0 | 0 | 0 | 0 |
| mm | 3.17 | | | | |

②

Screw the positioner R282.744.220 onto the soldering jig R282.740.000
Slide contact into positioner .
Insert solder gauge R282.862.060 between contact and cable .
Tighten and solder the contact .

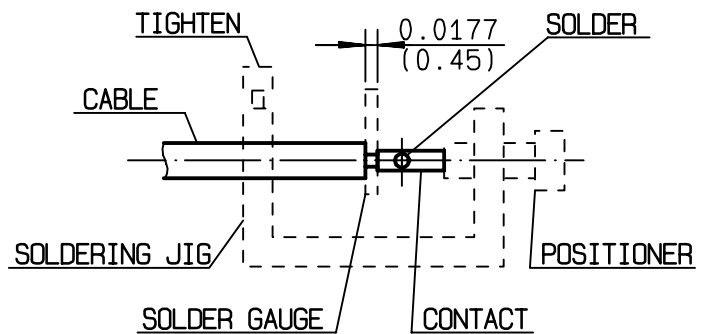

③

After cooling remove cable assembly from the jig .
Screw positioner R282.744.010 into the connector .
Slide cable into the connector until it bottoms againsts positioner R282.744.010 .
Tighten .
Put 3 rings of solder around the cable and solder .

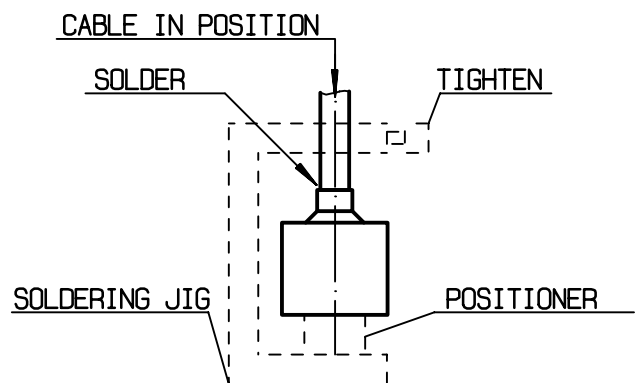

④

After cooling remove cable assembly from the jig .
Screw positioner cut R282.914.010
Cut the dielectric flush to clamp braid sleeve with tool R282.915.010.
Screw female dielectric insert tool onto connector and insert insulator with the dielectric plunger R282.730.043

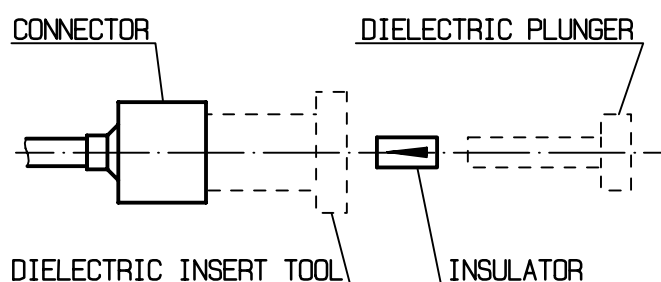

TRIQUES